

Technical Information

- CV** Check Valves
- SH** Shuttle Valves
- LM** Load/Motor Controls
- FC** Flow Controls
- PC** Pressure Controls
- LE** Logic Elements
- DC** Directional Controls
- MV** Manual Valves
- SV** Solenoid Valves
- PV** Proportional Valves
- CE** Coils & Electronics
- BC** Bodies & Cavities
- TD** Technical Data

General Description

Pilot Operated, Spool-Type Relief Valve. For additional information see Technical Tips on pages PC1-PC6.

Features

- Very high flow capacity
- Minimal pressure variation with flow change
- Full tank line back pressure capability, ideal for crossline relief applications
- Integral 250 micron pilot flow filter
- Hardened working parts for maximum durability
- Adjustable and tamperproof versions available
- All external parts zinc plated

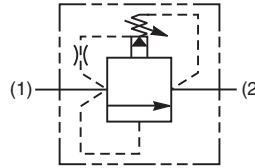
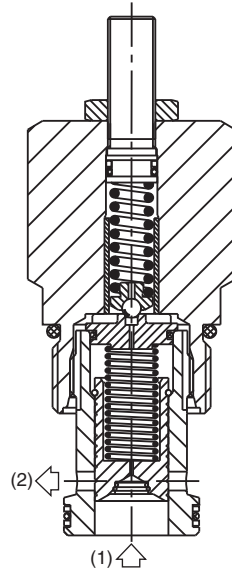
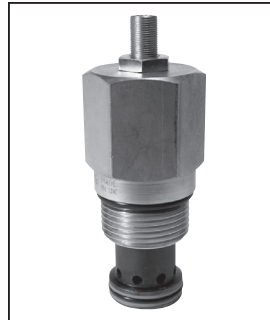

Specifications

Rated Flow	400 LPM (106 GPM)
Maximum Inlet Pressure	H - 10-210 Bar (145-3000 PSI) P - 10-420 Bar (145-6000 PSI)
Maximum Pressure Setting	420 Bar (6000 PSI)
Sensitivity: Pressure/Turn	H 30 Bar (435 PSI) P 55 Bar (800 PSI)
Maximum Tank Pressure	420 Bar (6000 PSI)
Leakage at 150 SSU (32 cSt)	100 ml/min. @ 100 Bar (1450 PSI)
Cartridge Material	All parts steel. All operating parts hardened steel.
Operating Temp. Range/Seals	-34°C to +121°C (Nitrile) (-30°F to +250°F) -26°C to +204°C (Fluorocarbon) (-15°F to +400°F)
Fluid Compatibility/Viscosity	Mineral-based or synthetic with lubricating properties at viscosities of 45 to 2000 SSU (6 to 420 cSt)
Filtration	ISO-4406 18/16/13, SAE Class 4
Approx. Weight	0.57 kg (1.26 lbs.)
Cavity	C16-2 (See BC Section for more details)
Form Tool	Rougher None Finisher NFT16-2F

Performance Curve

(Pressure rise through cartridge only)

Flow vs. Inlet Pressure

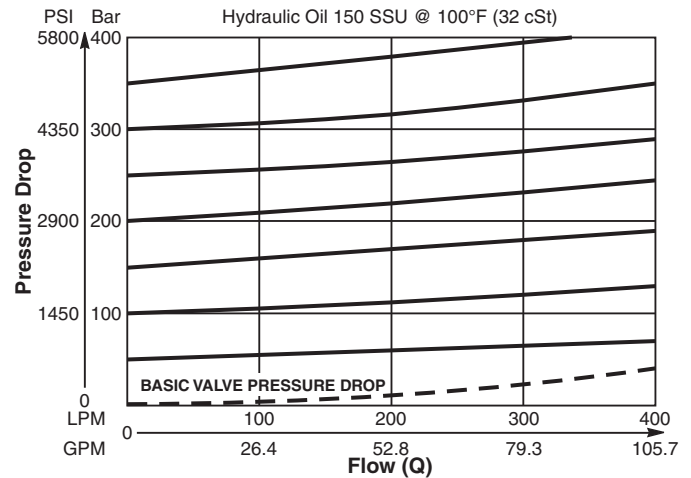

Dimensions Millimeters (Inches)

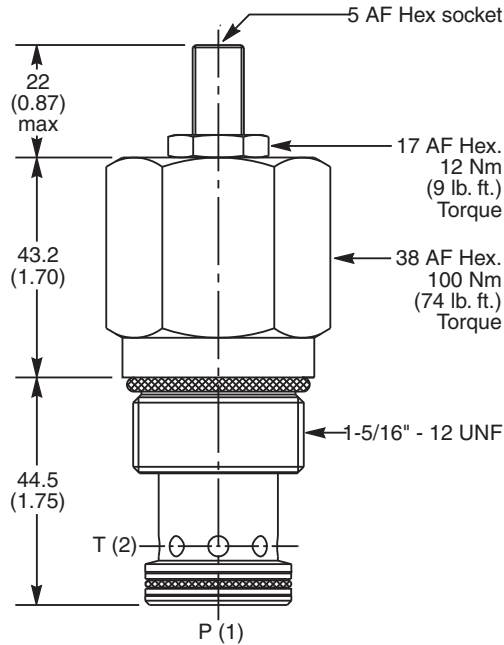

Ordering Information

A06G2							
16 Size Pilot Operated Relief Valve	Pressure Adjustment Range	Adjustment Style	Optional Flow @ Pressure Setting	Optional Pressure Setting	Seals	Body Material	Port Size

Code	Pressure Adjustment Range
H	10 - 210 Bar (145 - 3000 PSI)
P	10 - 420 Bar (145 - 6000 PSI)

Optional Pressure Setting	
Specify setting if required (Bar)	
A06G2H Standard Setting: 100 Bar (1450 PSI) @ 15 LPM (4.0 GPM)	
A06G2P Standard Setting: 200 Bar (2900 PSI) @ 15 LPM (4.0 GPM)	

Code	Body Material
Omit	Steel
A	Aluminum

Code	Adjustment Style / Kit No.
Z	Screw Adjust (Std.)
W	Knob Adjust
T	Tamper Resistant Cap (TC1130)

Code	Port Size	Body Part No.
Omit	Cartridge Only	
8T	SAE-8	(B16-2-*8T)
12T	SAE-12	(B16-2-*12T)
16T	SAE-16	(B16-2-*16T)

Optional Flow @ Pressure Setting	
If you require a maximum pressure setting at a flow rate, please enter it here in Liters per minute (LPM).	
Standard setting: 15 LPM (4.0 GPM)	

Code	Seals / Kit No.
N	Nitrile, Buna-N (Std.) / (SK30507N-1)
V	Fluorocarbon / (SK30507V-1)

* Add "A" for aluminum, omit for steel.