

Dimensions

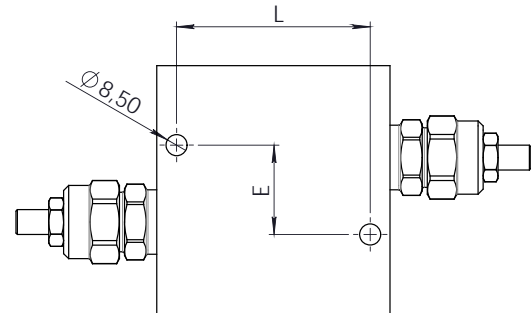

Size	A max	B	C	D	E	F	G	H BSP	L	N	Weight kg
03	207	94	38	28	65	100	40	1/2	-	8,5	1,41
04	207	94	38	28	36	100	40	3/4	78	8,5	1,36

Hydraulic Symbol

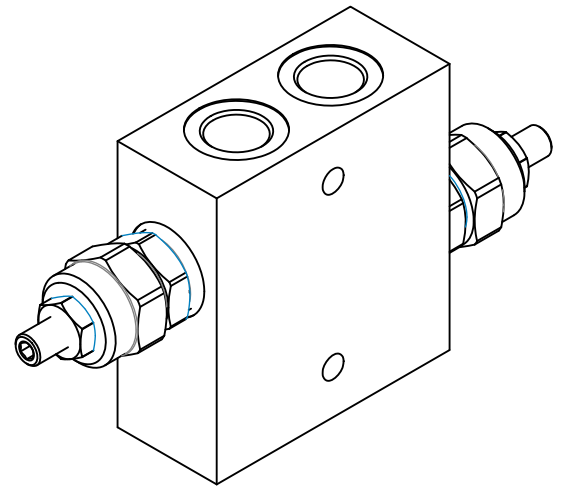
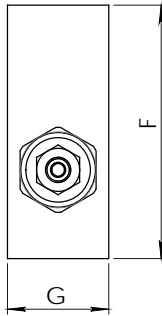
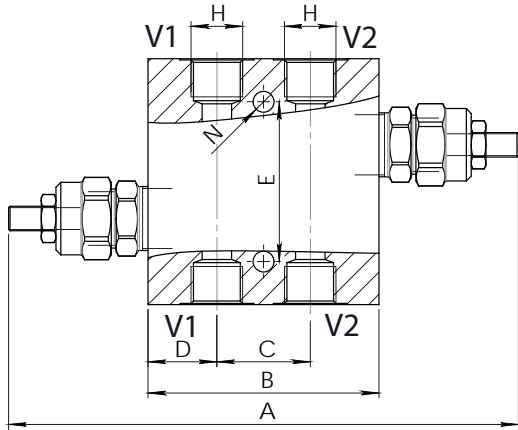
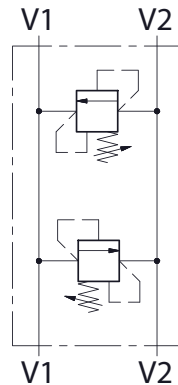

Curves

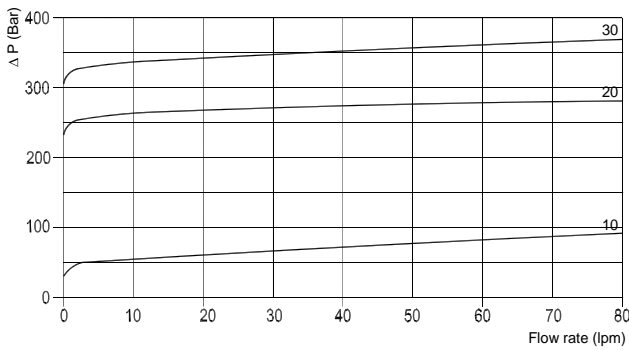

Features

Rated Flow	80 lpm
Max Pressure	260 bar

Materials: Zinc plated steel cartridge, hardened steel inner parts.
Aluminium manifold.

Ordering Code

DPRL 80 -- -- -

Port Size BSP		Spring (bar)	
03	1/2	10	5-50
04	3/4	20	30-260
		30	130-350

Adjustments

A		Socket Screw
B		Handknob
C		Tamperproof Cap

Ordering Code Example: DPRL800320A = 1/2 Port Size - 40-210 bar setting range, Socket screw adjustment.