

Dimensions

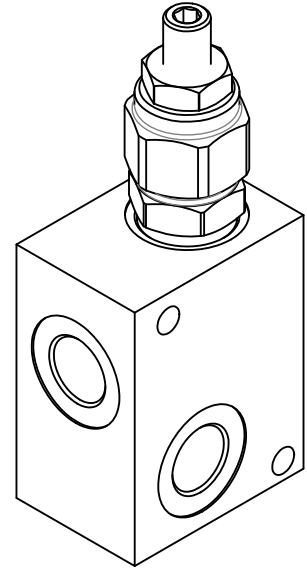

Size	A	B	C	D	E	F	G	H	L	M	N	Q	S	Weight kg
02	65	51	17	24	20	50	6	6,5	34	3/8	6	53	35	0,40
03	65	51	17	24	20	50	6	6,5	34	1/2	6	53	35	0,38

Hydraulic Symbol

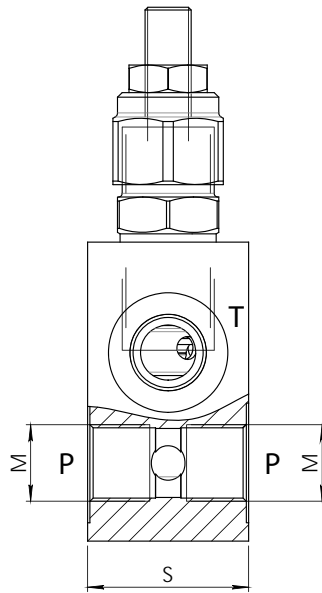
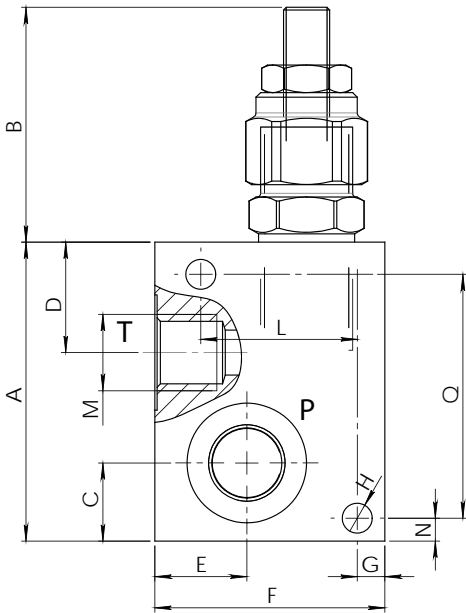
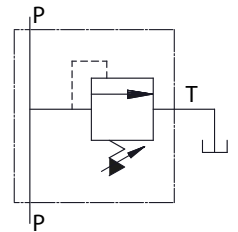

Curves

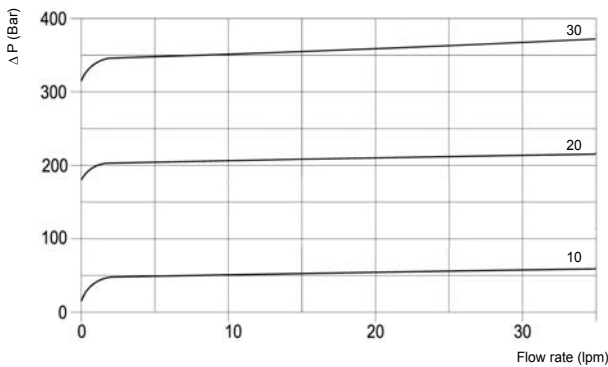

Features

Rated Flow	35 lpm
Max Pressure	350 bar

Materials: Zinc plated steel cartridge, hardened steel inner parts.
Aluminium manifold.

Ordering Code

PRL 35 -- -- -

Port Size BSP		Spring (bar)	
02	3/8	10	5-50
03	1/2	20	40-210
		30	100-350

Adjustments

A		Socket Screw
B		Handknob
C		Tamperproof Cap

Ordering Code Example: PRL350220A = 3/8 Port Size - 40-210 bar setting range, Socket screw adjustment.