

### Dimensions

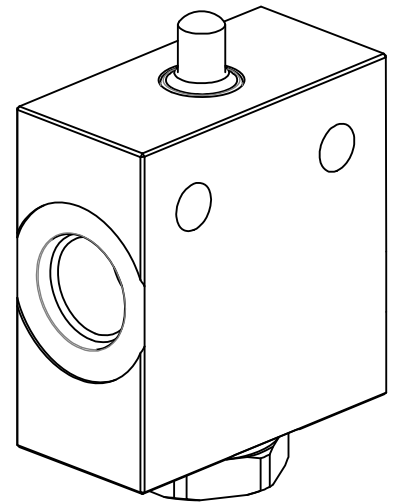

| Size | C    | D BSP | E  | F  | G  | H   | L  | M    | N  | P    | Q  | R  | Hex | Weight kg |
|------|------|-------|----|----|----|-----|----|------|----|------|----|----|-----|-----------|
| 02   | 83,9 | 3/8   | 60 | 30 | 35 | 8,5 | 43 | 13,5 | 8  | 12,3 | 63 | 30 | 27  | 0,80      |
| 03   | 96   | 1/2   | 70 | 35 | 40 | 8,5 | 51 | 13,5 | 12 | 12,3 | 75 | 37 | 32  | 1,28      |

### Hydraulic Symbol

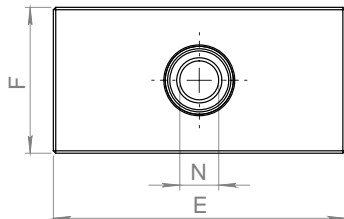
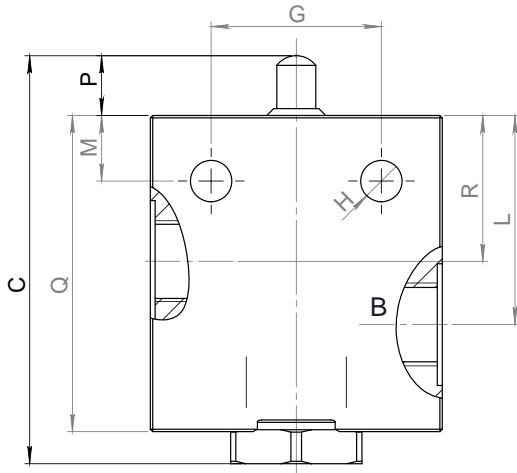
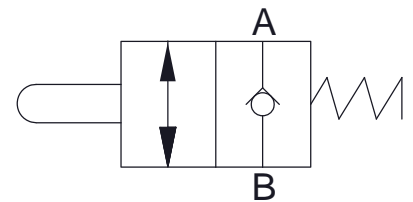

### Curves

**B → A**

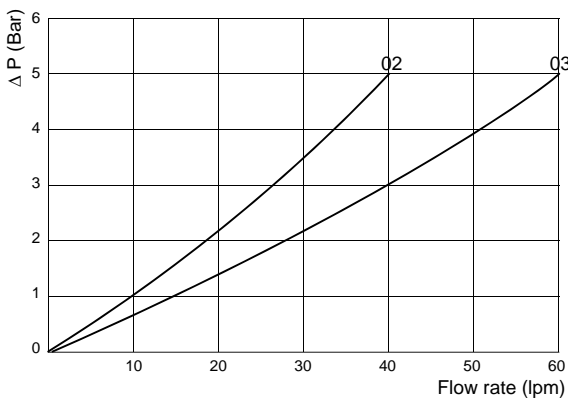

### Features

| Size                | 02  | 03  |
|---------------------|-----|-----|
| Max Pressure (bar)  | 350 | 350 |
| Max Flow Rate (lpm) | 30  | 60  |
| Stroke (mm)         | 10  | 12  |
| Spring Bias (Nm)    | 20  | 20  |

**Materials:** Zinc plated steel body, hardened steel inner parts.

### Ordering Code

**ESCS**

--

|           | Size BSP |
|-----------|----------|
| <b>02</b> | 3/8      |
| <b>03</b> | 1/2      |

**Ordering Code Example:** ESCS02 = 3/8 BSP.