

### Dimensions

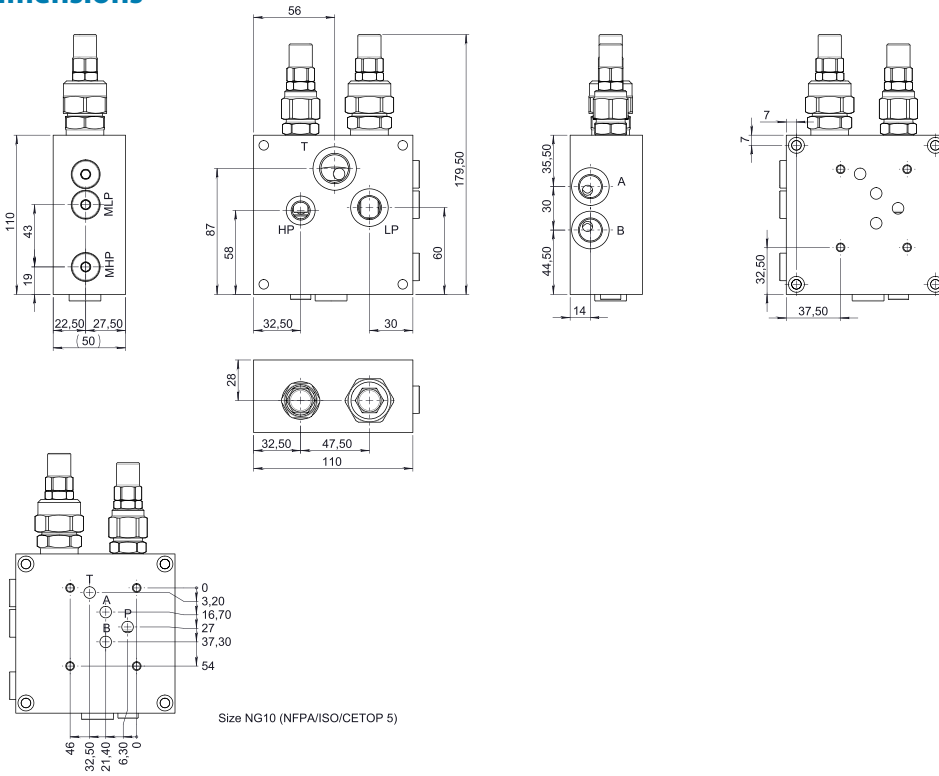

HP BSP	LP BSP	T BSP	A BSP	B BSP	M(HP) BSP	M(LP) BSP
1/4	3/8	1/2	3/8	3/8	1/4	1/4

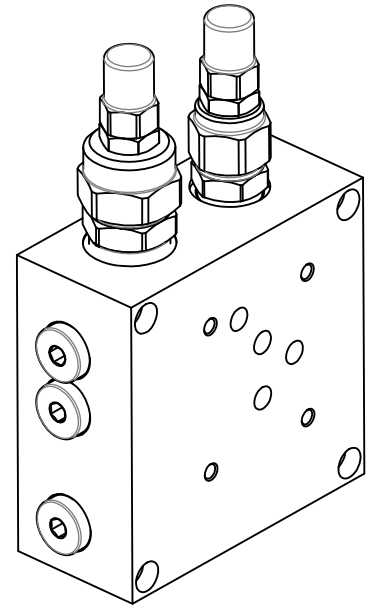

### Hydraulic Symbol

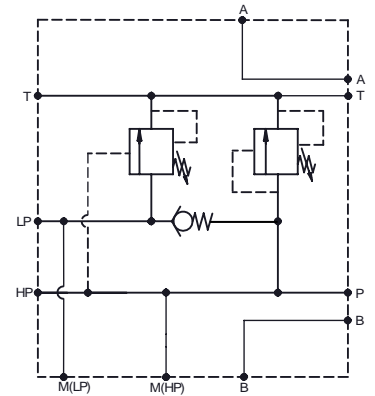

### Curves

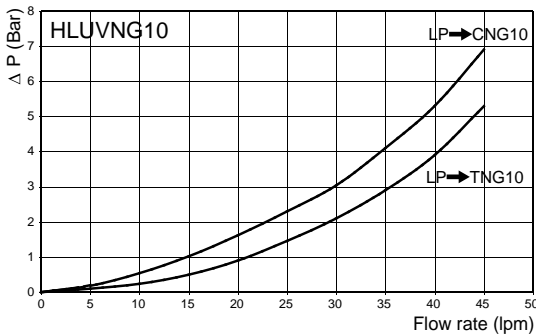

### Features

Max Flow Rate LP→C (lpm) **45**

**Materials:** Zinc plated steel cartridge, hardened steel inner parts.  
Aluminium manifold.

### Ordering Code

**HLUV NG10** -- --

#### LP - Spring (bar)

<b>10</b>	5-50
<b>20</b>	20-260

#### HP - Spring (bar)

<b>20</b>	40-210
<b>30</b>	100-350

**Ordering Code Example:** HLUVNG102030 = Hi-Low 1/2 BSP - LP valve 20-260 bar, HP valve 100-350 bar.