

HYDRAULIC SELECTOR VALVE РАСПРЕДЕЛИТЕЛИ ГИДРАВЛИЧЕСКИЕ

Type: SV80
Type: SV120

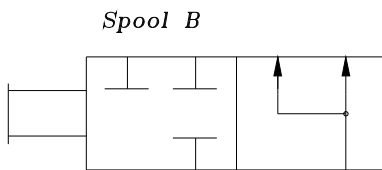
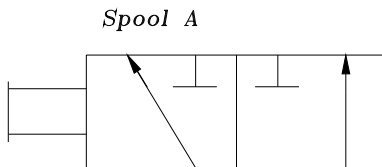

Spool "A" offer a simple method of directing system flow to one or the other of two separate line. Since the "A" spool is of open-crossover design, they should be shifted before pressure is applied. Spool "D" can be used with a 3-position four way control valve to provide a float or free wheeling condition. Application examples include plows, loaders and certain winches.

Specifications

1. Operating pressure _____ 3000 PSI (210 bar) max.

2. Capacity (Nominal)

SV80 _____ 20 GPM (75 l/min)

SV120 _____ 30 GPM (113 l/min)

Fluid recommendations

Premium grade hydraulic oil with 60 SUS (10 CST) to 1000 SUS (216 cst) viscosity at operating temperature per VG32.

Seals

standard _____ BUNA N

Temperature

Under normal conditions of operation, fluid temperature should not exceed 160°F (71°C). In no instance should temperature exceed 180°F (82°C).

Ports _____ SAE or BSP

Mounting position _____ unrestricted

Weight

SV80 _____ 3.2 lbs. (1.4 kg)

SV120 _____ 5.4 lbs. (2.4 kg)

Leakage _____ at 1000 PSI (70 bar) less than 20 cu.in. (322cc)

selector valve SV80

selector valve SV120

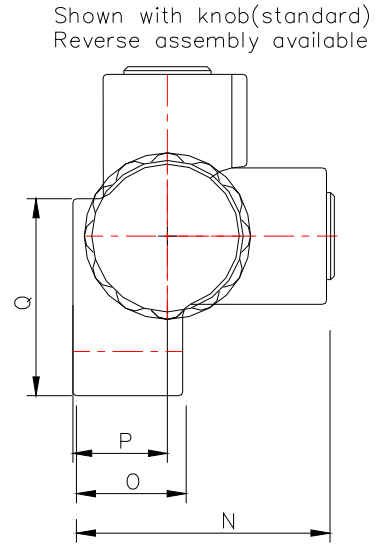
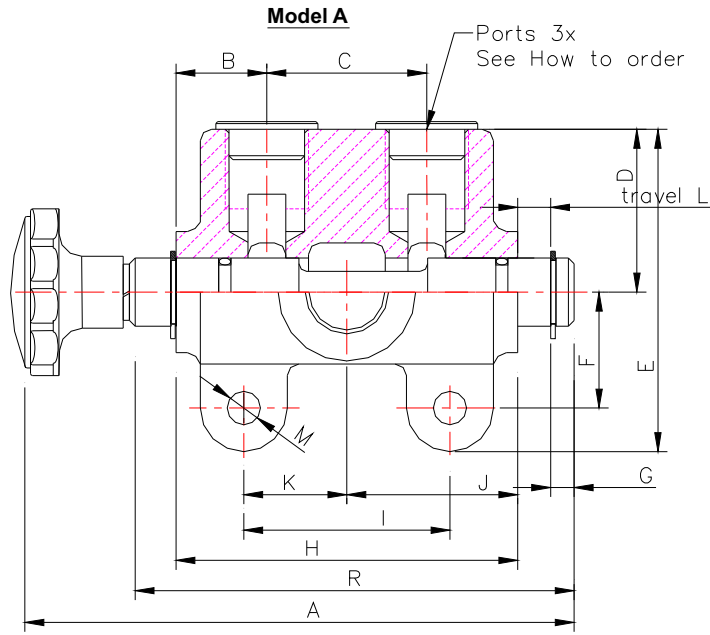
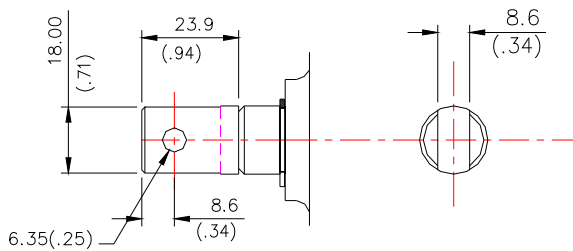

Table 1

Model	A	B	C	D	E	F	G	H	I	J	K	L	M	N	O	P	Q	R
SV80	147.1	24.6	41.4	42.9	84.1	30.2	6.4	90.4	54.1	45.2	26.9	7.9	8.9	66.6	28.5	25.4	50.8	117.4
	5.79	.97	1.63	1.69	3.31	1.19	.25	3.56	2.13	1.78	1.06	.31	.35	2.62	1.12	1.00	2.00	4.62
SV120	168.2	28.7	53.9	52.3	101.6	38.1	6.4	111.3	76.2	55.6	38.1	9.7	8.9	66.6	28.5	25.4	58.7	138.2
	6.62	1.13	2.12	2.06	4.00	1.50	.25	4.38	3.00	2.19	1.50	0.38	.35	2.62	1.12	1.00	2.31	5.44

Optional Clevis

Both valves are available with a Clevis actuator in place of the standard knob, or can be supplied with neither.



Optional Spring

Spool "A" only is available with an offset spring for intermittent actuation. It is installed on the Spool end opposite that of the actuator and returns the spool to the "IN" position when released. (The spring mechanism is open to atmosphere).

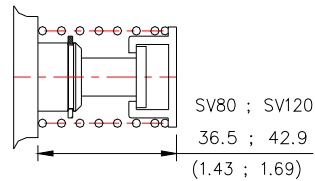

ORDER CODE:

SV . . . A S8 K R - S

selector valve (80 or 120)

spool type (A or D)

port sizes (S or G)

SV 80 (S8=SAE8; S10=SAE10; G12=G1/2)
SV120 (S12=SAE12; G34=G3/4)

actuator (Knob-standard)

K-Knob; C-Clevis; L-Less knob and clevis

R-Reverse Assembly

Spring offset
(spool A only)