

Dimensions

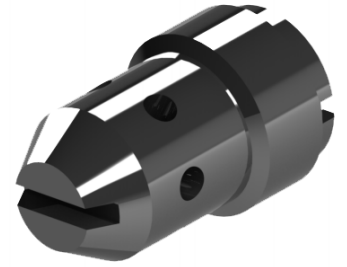

Hydraulic Symbol

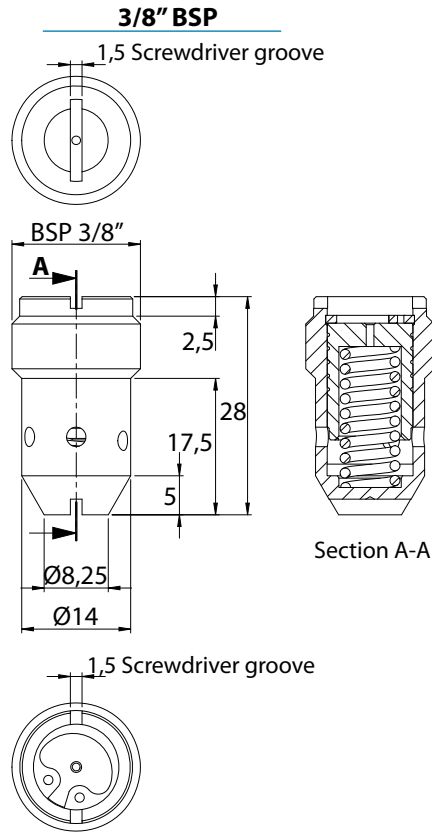
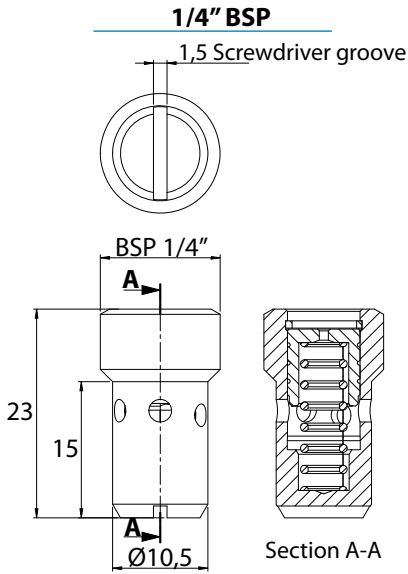
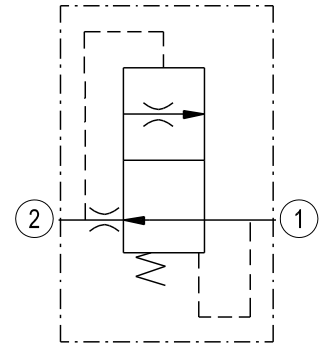

Features

Max Pressure 350 bar

Materials: Steel cartridge, hardened steel inner parts.

Ordering Code

DVF -- -- --

Size	Size BSP	Flow Rate (lpm)	
		01	02
01	1/4	1	2
02	3/8	1,5	-
A		2	-
AB		3	3
B		4	4
C		5	5
D		6	6
E		7	7
F		8	8
G		9	9
H		10	10
I		-	11
J		-	12
K		-	13
L		-	14
M		-	15
N		-	16
O		-	17
P		-	18
Q		-	19
R		-	20
S		-	-
T		-	-

Setup

	Cartridge only
MF	Cartridge+Male/Female fitting *
FF	Cartridge+Female/Female fitting *

* For line fittings dimensions refer to page 127/00

Ordering Code Example: DVF01B = 1/4" BSP cartridge, 2 lpm at 60 bar.