

### Dimensions

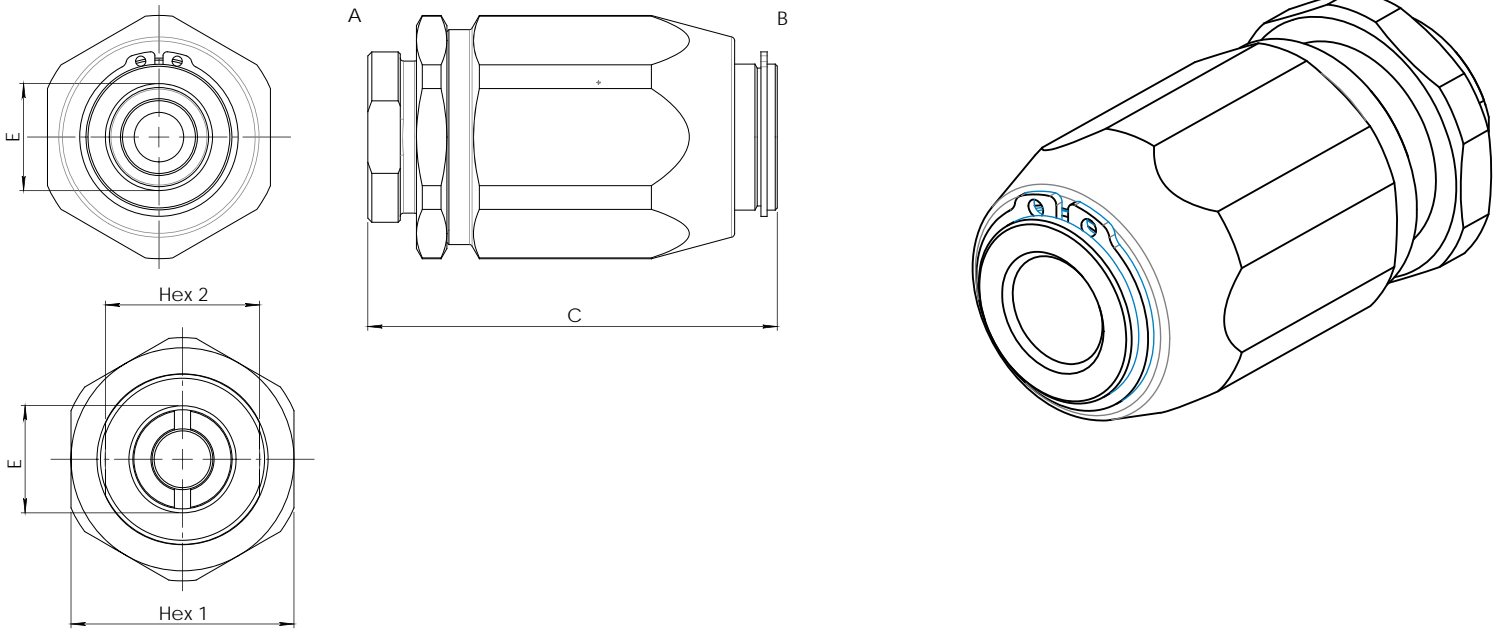

Size	C	E BSP	Hex 1	Hex 2	Weight kg	Max Pressure bar	Max Flow Rate A→B lpm	Max Flow Rate B→A lpm	Cracking Pressure bar
<b>01</b>	65	1/4	32	22	0,29	350	30	30	0,5
<b>02</b>	75	3/8	38	27	0,48	350	40	50	0,5
<b>03</b>	80	1/2	41	30	0,59	350	50	80	0,5
<b>04</b>	101	3/4	55	38	1,34	300	80	110	0,5
<b>05</b>	115	1	65	46	2,35	250	110	160	0,5

### Hydraulic Symbol

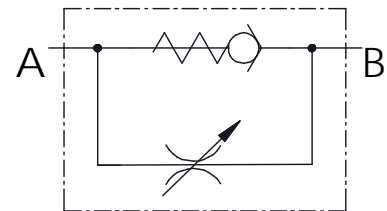

### Curves

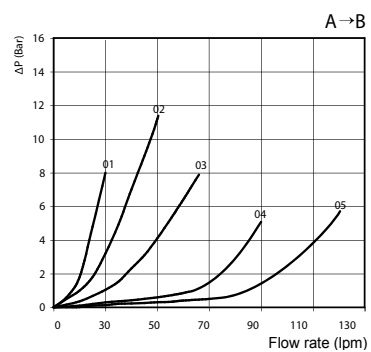
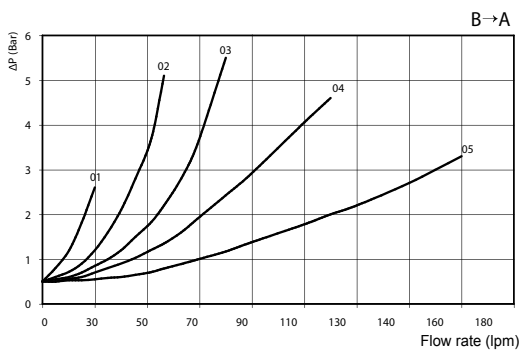

**Materials:** Zinc plated steel body, hardened steel poppet.

### Ordering Code

**FRUB**

--

#### Size BSP

<b>01</b>	1/4
<b>02</b>	3/8
<b>03</b>	1/2
<b>04</b>	3/4
<b>05</b>	1

**Ordering Code Example:** FRUB03 = 1/2 BSP.