

Dimensions

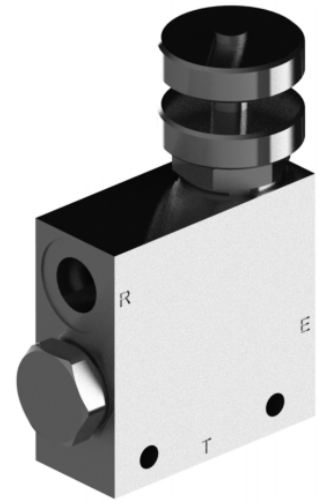

Size	E-R-T	A	B	C	D	F	G	H	I	L	O	S	Z
01	1/4	70	70	9	56	33,5	15,5	27	8	44	12	30	6,5
02	3/8	70	70	9	56	33,5	15,5	27	8	44	12	30	6,5
03	1/2	90	90	24	72	39	20	30	6	64	13	40	6,5
04	3/4	110	110	24	87	44	30	35	7	88	10	50	8,5
05	1	110	110	37,5	87	45	28	46	10	88	10	50	8,5

Hydraulic Symbol

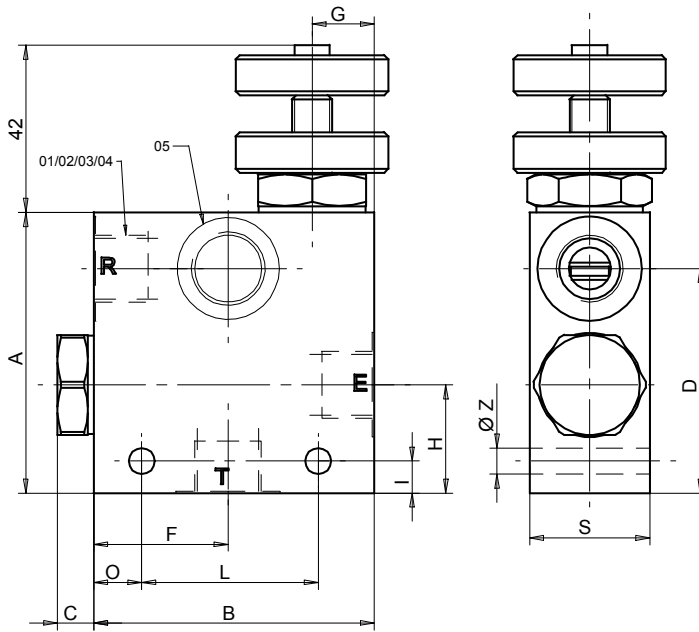
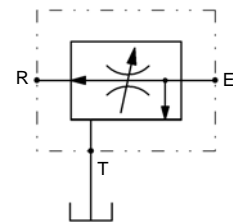

Curves

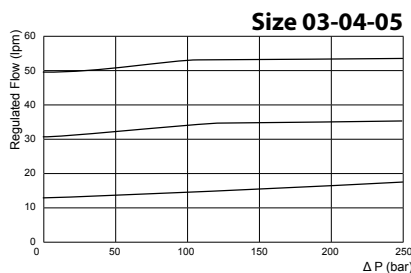
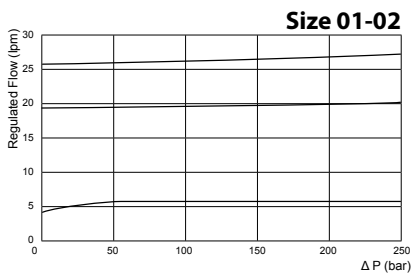

Features

Size	01	02	03	04	05
Max Pressure (bar)	210				
Ports E-R-T	G 1/4	G 3/8	G 1/2	G 3/4	1"
QE max (lpm)	40	40	90	150	280
QR max (lpm)	25	25	55	90	190

Materials: Aluminium body, hardened steel inner parts.

Ordering Code

PVET **--**

	Size BSP
01	1/4
02	3/8
03	1/2
04	3/4
05	1"

Ordering Code Example: PVET03 = 1/2 BSP.