

Dimensions

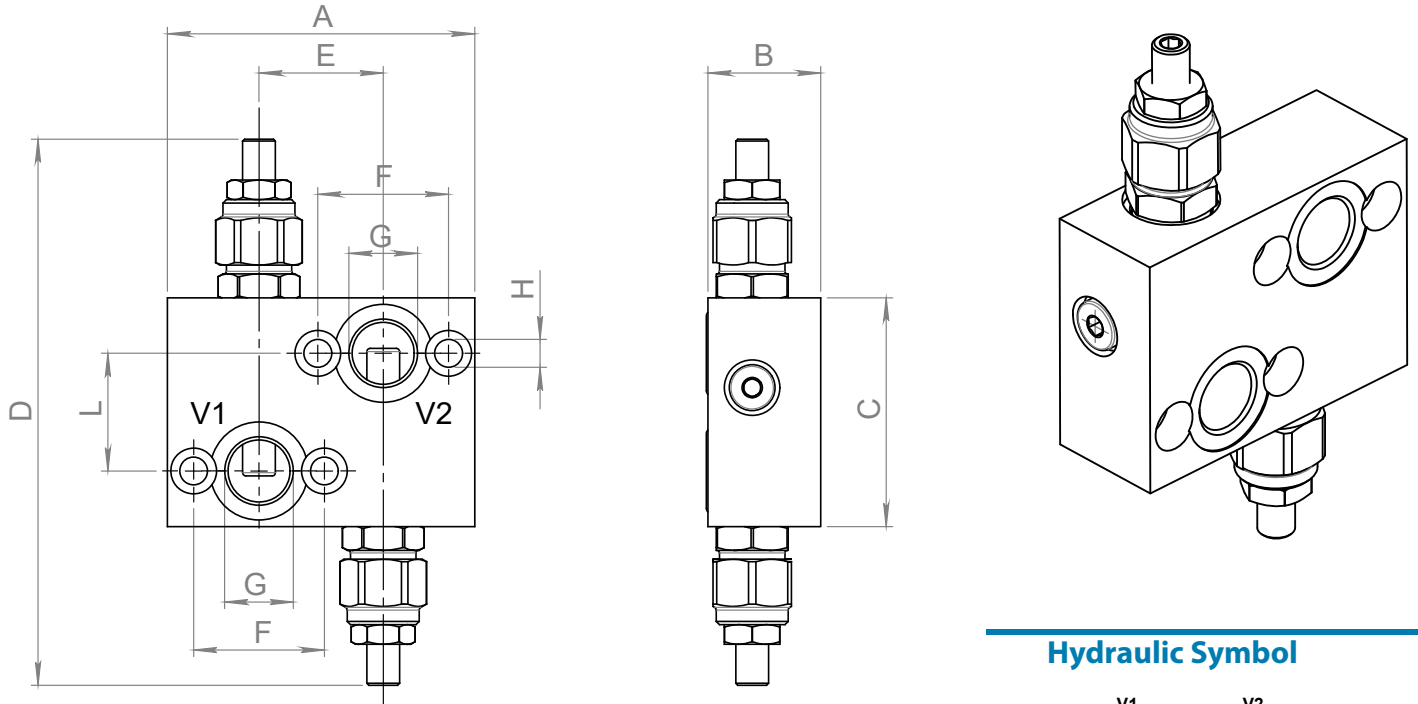

Size	A	B	C	D	E	F	G BSP	H	L	Weight kg
03	94	35	70	167	36	40	1/2	8,5	36	0,75

Hydraulic Symbol

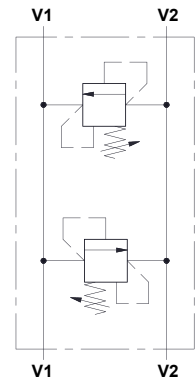

Curves

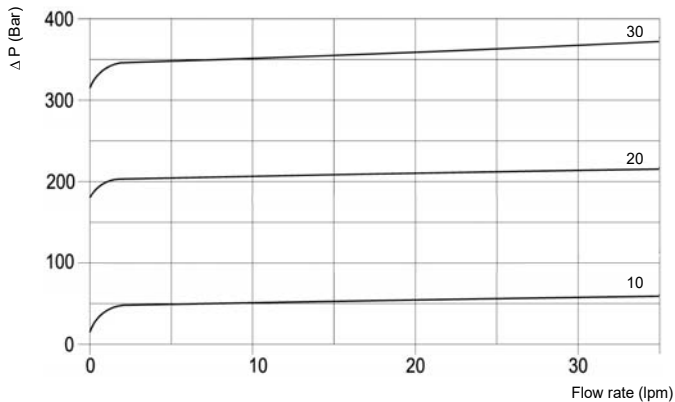

Features

Rated Flow	35 lpm
Max Pressure	350 bar

Materials: Zinc plated steel cartridge, hardened steel inner parts.
Aluminium manifold.

Ordering Code

DPROMP-R35 -- -- -

Port Size BSP		Spring (bar)	
03	1/2	10	5-50
		20	40-210
		30	100-350

Adjustments

A		Socket Screw
B		Handknob
C		Tamperproof Cap

Ordering Code Example: DPROMP-R350320A = 1/2 Port Size - 40-210 bar setting range, Socket screw adjustment.