

ISE90 - Overcenter valve

Pilot assisted relief with check
90 L/min (23 USgpm) • 270 bar (4000 psi)

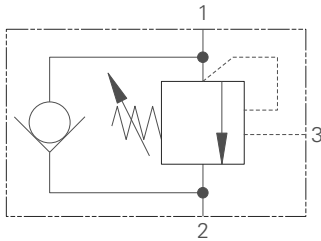

Sectional view

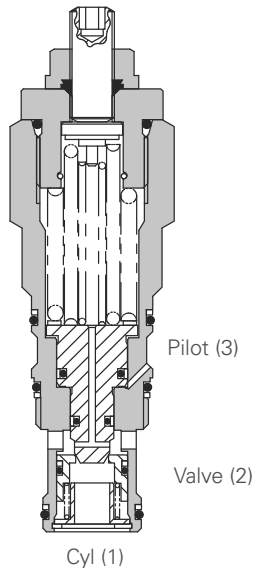

Operation

The check section allows free flow into the actuator then holds and locks the load against movement. The pilot assisted relief valve section will give controlled movement when pilot pressure is applied. The relief section is normally set to open at a pressure at least 1.3 times the maximum load induced pressure but the pressure required to open the valve and allow movement

depends on the pilot ratio of the valve. For optimization of load control and energy usage, a choice of pilot ratios is available.

The pressure required to open the valve and start actuator movement can be calculated as follows:

$$\text{Pilot Pressure} = \frac{(\text{Relief Setting}) - (\text{Load Pressure})}{\text{Pilot Ratio}}$$

Features

Cartridge is economical and fits simple cavity. Allows quick, easy field service - reduces down time. Interchangeable with pilot check valve of a similar size.

Pilot ratio

4:1 Best suited for applications where the load remains relatively constant.

Other ratios available on request.

Performance data

Ratings and specifications

Figures based on: Oil Temp = 40°C Viscosity = 32 cSt (150 SUS)

Rated flow	90 L/min (23 USgpm)
Max relief setting	350 bar (5000 psi)
Max load induced pressure:	270 bar (4000 psi)
Cartridge material	Working parts hardened and ground steel. External steel surfaces zinc plated.
Mounting position	Unrestricted
Cavity number	A20092-T2A
Torque cartridge into cavity	60 Nm (44 lbs ft)
Weight	0.42 kg (0.92 lbs)
Seal kit number	SK1093 (Nitrile) SK1093V (Viton®)
Recommended filtration level	BS5540/4 Class 18/13 (25 micron nominal)
Operating temperature	-30° to +90°C (-22° to +194°F)
Leakage	0.3 milliliters/min nominal (5 dpm)
Nominal viscosity range	5 to 500 cSt

Viton is a registered trademark of E.I. DuPont.

Pressure drop

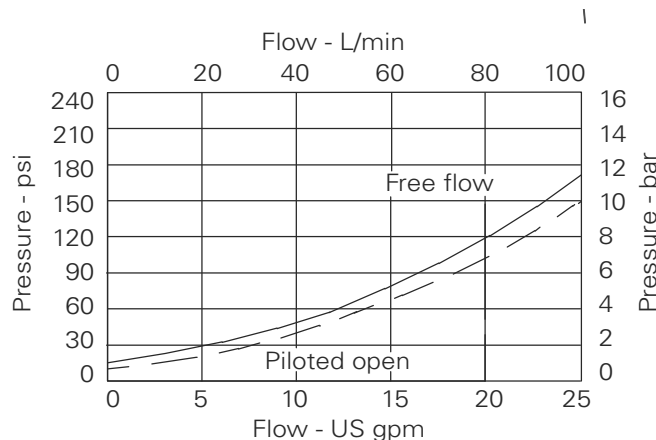

Description

Overcenter valves give static and dynamic control of loads by regulating the flow into and out of hydraulic actuators. When installed close to or within an actuator, the overcenter valve will stop runaway in the event of hose burst and if open center directional control valves are used, will allow thermal expansion relief of the hydraulic fluid.

The overcenter cartridge is ideal for mounting directly into a cavity machined in the body of the cylinder, motor or rotary actuator. The cartridge can also be mounted directly to the ports via a specifically machined body as part of a Hydraulic Integrated Circuit or single unit, or contained within one of our standard line bodies.

Single overcenter valves are normally used when the load is unidirectional, for example an aerial platform or crane and dual overcenter valves are used for controlling loads in both directional for motor applications or for cylinders going over center.

Where measurements are critical request certified drawings. We reserve the right to change specifications without notice.

ISE90 - Overcenter valve

Pilot assisted relief with check
90 L/min (23 USgpm) • 270 bar (4000 psi)

Model code

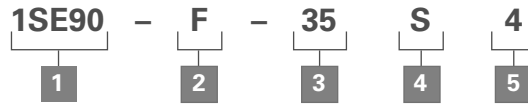

1 Function

1SE90

2 Adjustment means

F - Screw Adjustment

N - Fixed - State pressure setting required

For fixed versions add setting in 10 bar increments to end of part number. Subject to a ±10% tolerance.

3 Pressure range @ 4.8 L/min

Note: Code based on pressure in bar.

20 - 70-225 bar
Std setting 100 bar

35 - 200-350 bar
Std setting 210 bar

Std setting made at 4.8 L/min

4 Seals

S - Nitrile (For use with most industrial hydraulic oils)

SV - Viton (For high temperature and most special fluid applications)

5 Pilot ratio

4 - 4:1

8 - 8:1

Other ratios available upon request

Dimensions

mm (inch)

Cartridge only

Basic code

1SE90

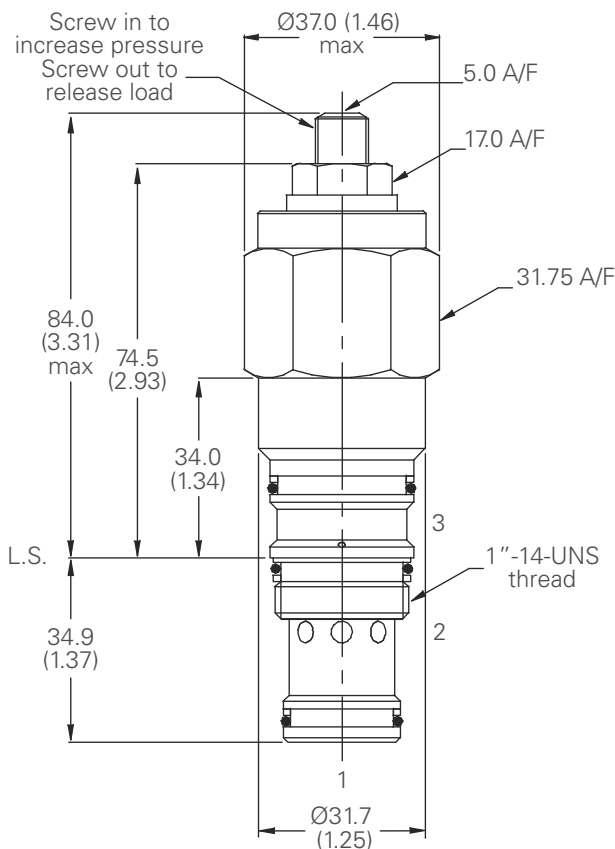

Note: Tightening torque of "F" adjuster locknut - 20 to 25 Nm.

Cavity

Model A20092-T2A

Form Drill TD-2A

Form Reamer TR-2A

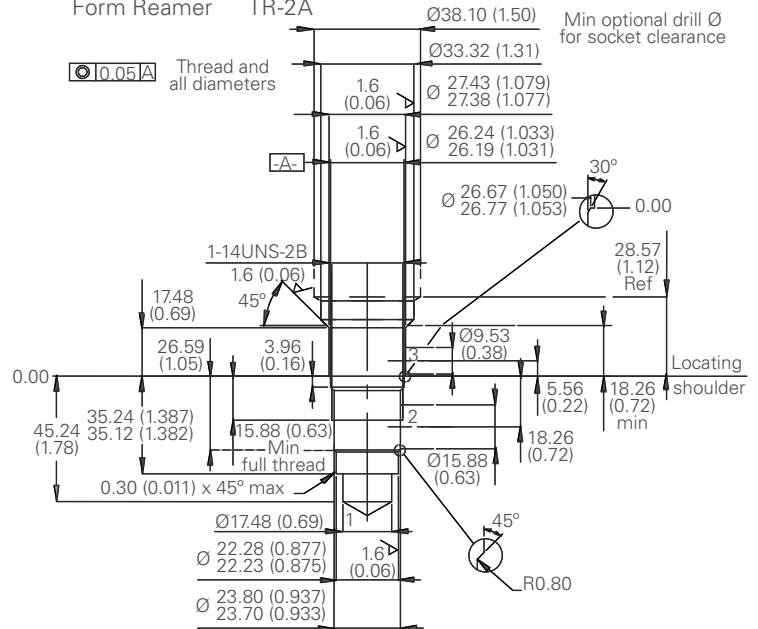

Where measurements are critical request certified drawings. We reserve the right to change specifications without notice.