

Dimensions

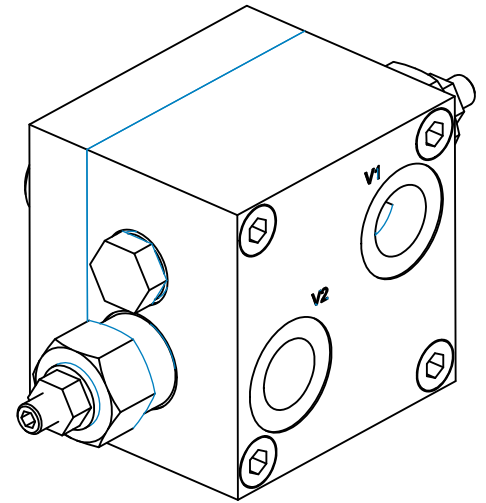

Hydraulic Symbol

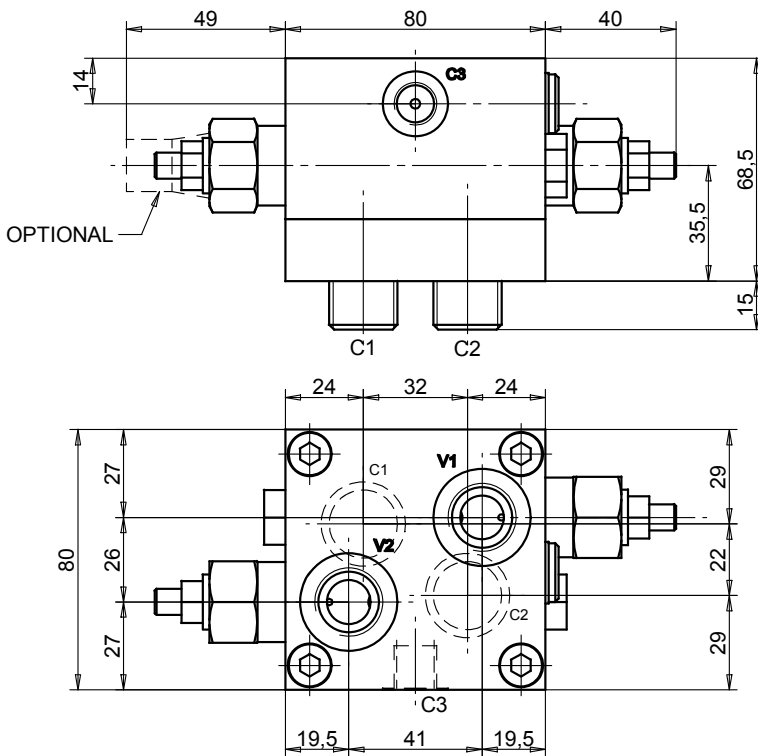
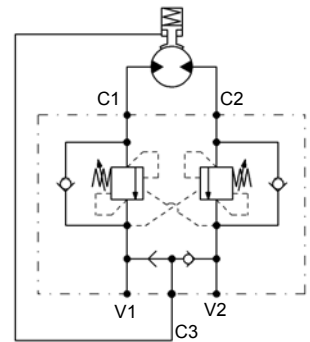

Curves

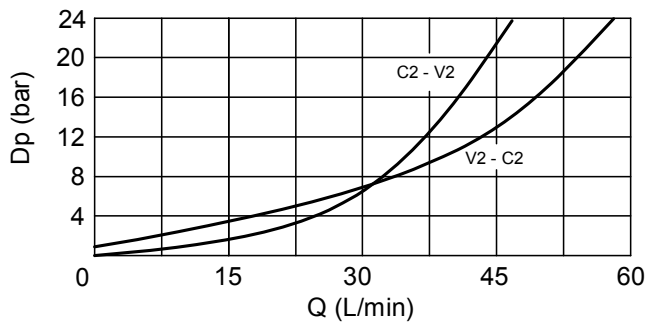

Materials: Zinc plated steel cartridge, hardened steel inner parts.
Aluminium manifold.

Features

Max Flow	60 lpm
Max Pressure	250 bar
Pilot Ratio	4,2:1 Standard
Ports	V1-V2: G 1/2 C1-C2: G 1/2 C3: G 1/4
Std. Pressure range	100 - 350 bar

Ordering Code

CBDLSFOMS 03