

Dimensions

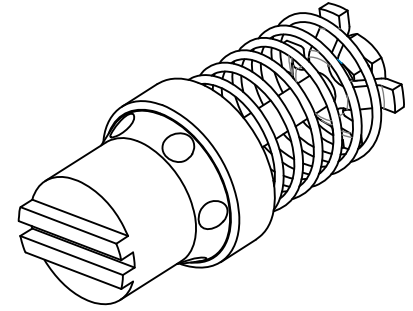

Hydraulic Symbol

Size	A (BSP)	Max Flow (lpm)	Max Pressure (bar)	B	C	E	G	L	M	Hex 1	Hex 2	Tightening Torque (Nm)	Weight (kg)
01	1/4	15	300	10	4	6,5	13,5	39	10	5,5	5,5	6	0,013
02	3/8	35	300	11,5	6	7	15	45	14	6	7	8	0,024
03	1/2	65	300	16	6	7	16,5	51	18	6	7	12	0,037
04	3/4	150	300	20	8	9,5	21,5	62	23	6	7	15	0,070
05	1	250	250	26	14	15	25	82	28,5	8	8	20	0,170
06	1-1/4	400	250	33	17,5	20,5	31,5	95	35	10	10	25	0,270

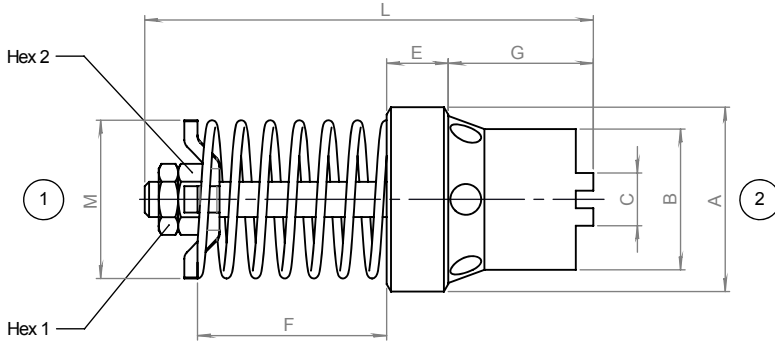
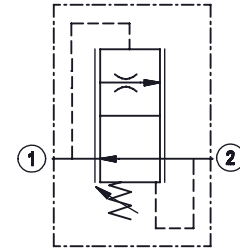

Curves

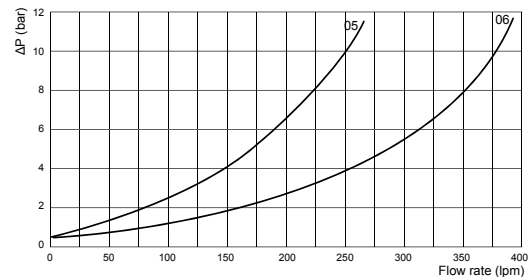
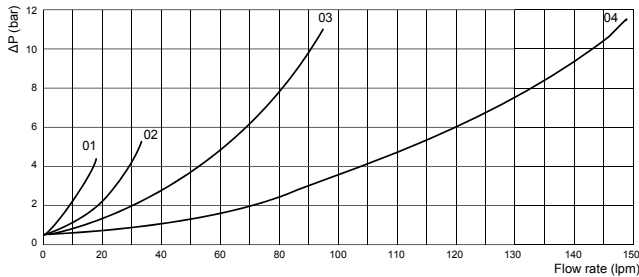

Materials: Steel cartridge.

Ordering Code

VRD -- -- --

Size	Size BSP
01	1/4
02	3/8
03	1/2
04	3/4
05	1
06	1 - 1/4

Setting Range	01	02	03	04	05	06
A	1 - 1,6	2,5 - 4	16 - 21	37 - 50	80 - 100	160 - 210
B	1,5 - 2,5	3,8 - 6,3	20,5 - 28	48 - 65	100 - 130	205 - 250
C	2,4 - 4	6,1 - 10	27,5 - 37	63 - 90	128 - 162	245 - 280
D	3,9 - 6,3	9,8 - 16	36,5 - 50	88 - 120	160 - 200	270 - 340
E	6,2 - 10	15,8 - 25	48 - 65	115 - 150	195 - 250	330 - 400
F	9,5 - 15	24,5 - 35	/	/	/	/

Setup

	Cartridge only
MF	Cartridge+Male/Female fitting *
FF	Cartridge+Female/Female fitting *

* For line fittings dimensions refer to page 127/05

Ordering Code Example: VRD03D = 1/2" BSP cartridge, 36,5 - 50 lpm flow rate setting range