

HYDRAULIC DIRECTIONAL CONTROL VALVES РАСПРЕДЕЛИТЕЛИ ГИДРАВЛИЧЕСКИЕ

Type: P120



Description

Назначение и область применения

For starting, controlling and stopping the working fluid between the generator of pressured flow, the consumers and the Tank. Предназначен для изменения направления потока, ограничения давления рабочей жидкости в гидротлиниях, разгрузки насоса в нейтральной позиции золотников.

Specifications

Основные показатели:

1. Valve monoblock	моноблок
Конструктивное выполнение	
2. Mounting	3 bolts M10
Крепление	
3. Pressure connections	internal thread
Присоединительные отверстия	внутренние резьбы
4. Ambient temperature	-40C...+60C
Температура воздуха	
5. Pressure medium	mineral oil based hydraulic oil
Рабочая жидкость	
6. Viskosity	12...800 mm ² /s permissible range
Кинематическая вязкость	20...100 mm ² /s recommended range
7. Fluid temperature	- 15C...+80C
8. Filtration	Oil contamination 10 to NAS1638
9. Max. operating pressure	P = 250 bar
Давление max. bar	T = 50 bar
	A, B = 300 bar
	30 cm ³ /min at 120 bar
10. Leakage	
Внутренние потери (A, B – T)	
11. Nominal flow	120 l/min (see “operating” diagram)
Разход рабочей жидкости	
12. Spool stroke	± 10 mm, L12 = ± 10 mm +6 mm
Ход золотника	
13. Actuating force	< 300 N in spool axis direction
Усилие на движения золотника	

directional control valve P120
parallel

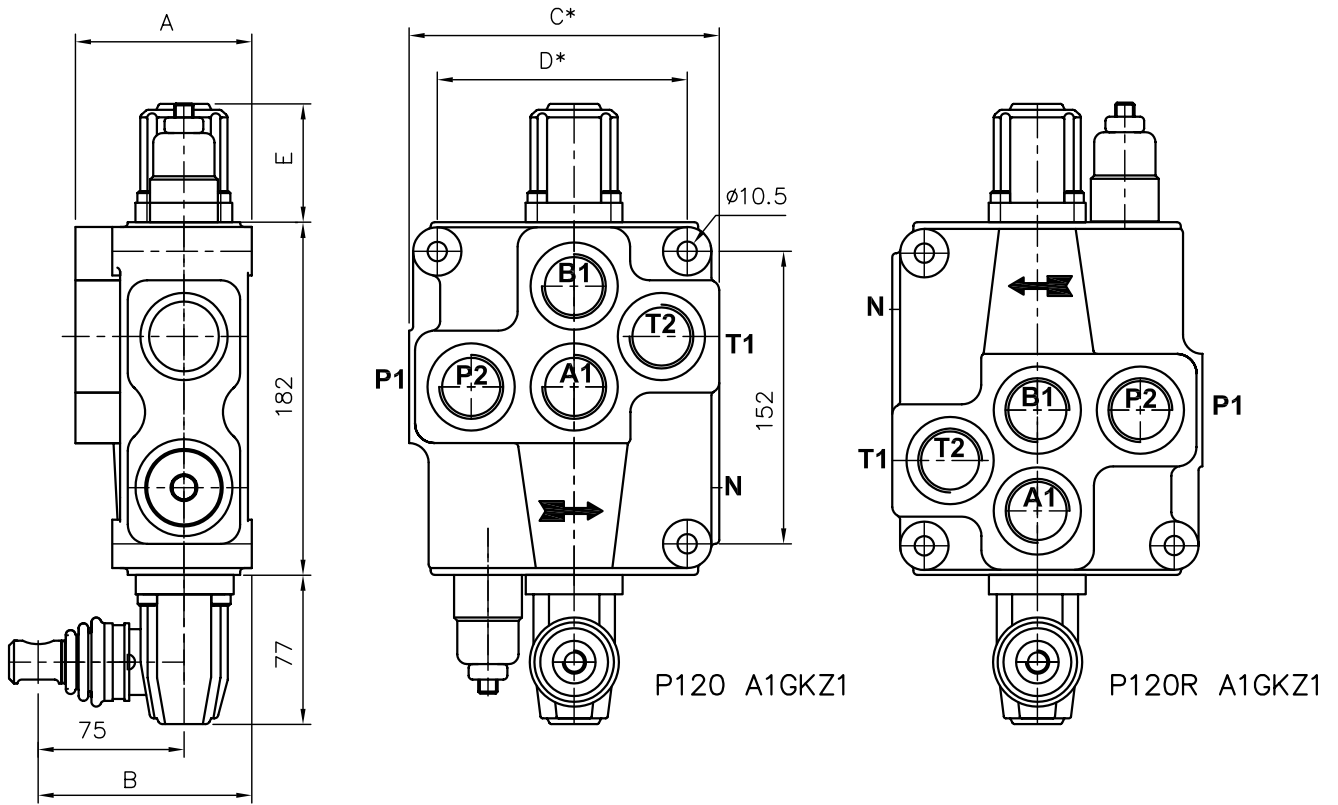

* for each next spool + 53 mm

Table 1

	A	B	C	D	P1	P2	T1	T2
P120	92	110	160	129	+	+	+	+

Table 2

spool control фиксация золотника	E
1; 2, 3, 4; 5; 6; 7; 8; 9; 10; 11;	64
12	74

02 P120 1 A 1 L 12 G KZ1 H E C2 -11

number of spools

hydraulic directional control valve P120

parallel distribution (parallel)

spool type—distribution

spool control (table 2)

second spool distribution (table 1)

second spool control (table 2)

ports threads (table 5)

lever options (table 6)

operation features (table 4)

electric microswitch (table 3)

carry over center (table 7)

connection ports in use (table 8)

directional control valve P120
parallel

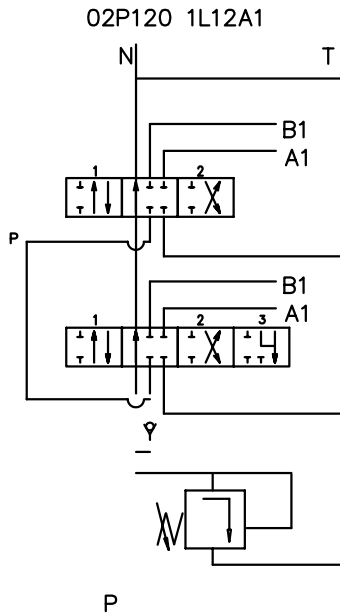

Table 3

code	Number of spools
P	1
02, 2	2
03, 3	3

ets.

Table 4

code	way of distribution ; распределение потока
1	parallel ; параллельное
(2)	(tandem(series parallel) ; серийно-параллельное)

Table 5

code	spool type
A	
B	
C	
D	
E	
F	
G	
H	
M	
N	
O	
P	
Q	
R	
S	
T	
L	

Table 6

code	spool control
1	
2	
3	
4	
5	
6	
7	
8	
9	
10	
11	
12	
13	

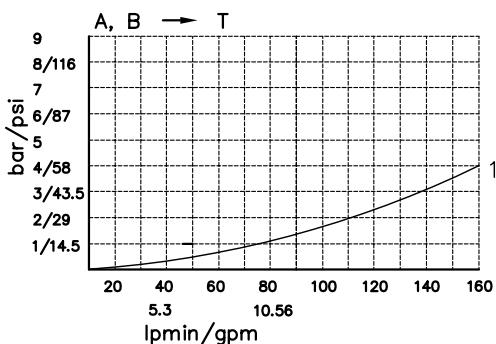
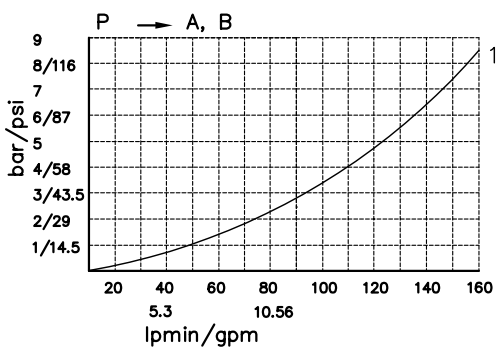
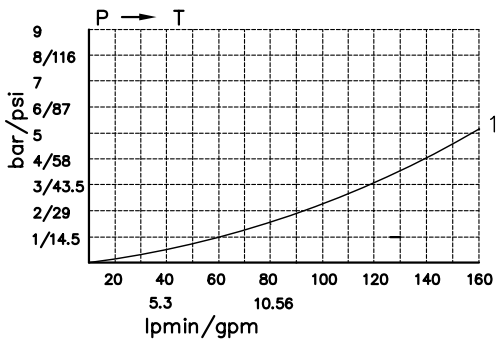

Table 7

code	с микро шалтер ; incorporated microswitch
E	 <div style="display: inline-block; vertical-align: middle;"> <p>mikroswitch type Omron-V 165 I C5</p> </div> 

Table 8

code	другое управление ; operation feature
P	 <p>пневматическое on-off pneumatic control ; 5-10 bar ; ports G1/4</p>
H	 <p>гидравлическое on-off hydraulic control ; pn = 5 - 20 bar ; ports G1/4</p>

directional control valve P120
parallel

treads for conection

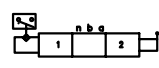
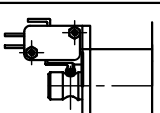
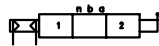
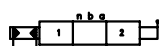
Table 9

outlets/ports/	metric	BSP	SAE	NPT
P, A, B, T	M33x2	G 1"	SAE 16	1 - 11.5
N	M36x1.5	-	-	-

Table 10

code	with thread M12	code	with cange ø12	code	with cange ø12
KZ		KY		KI	
KZ1		KY1		KI1	
KZ0		KY0		KI0	
KZ01		KY01		KI01	

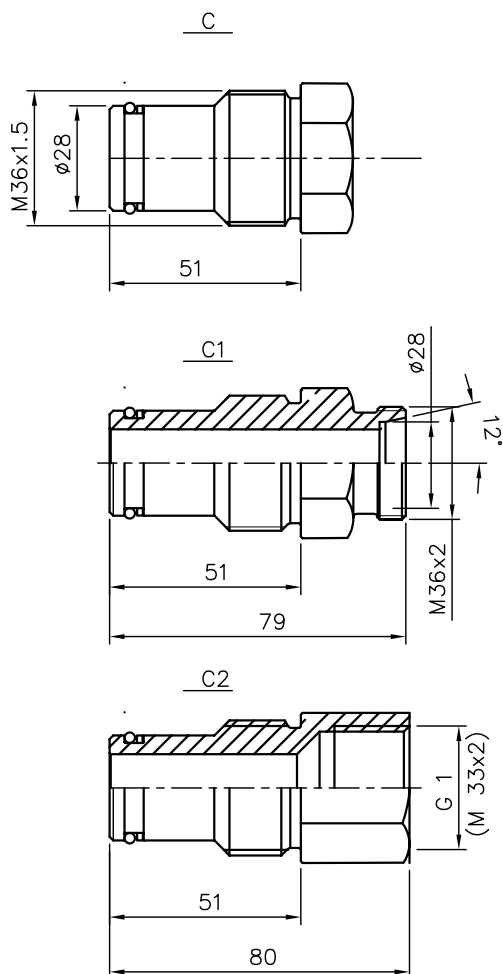

Table 11

code	metric
X	without N
-	with N, but closed
C	with N, closed center
C1	with N -carry over for ermeto
C2	with N-carry over, internal thread

Table 12

code	ports for connection in uze
11	P1 ; T1
12	P1 ; T2
21	P2 ; T1
21	P2 ; T1