



Description

Назначение и область применения

For starting, controlling and stopping the working fluid between the generator of pressured flow, the consumers at the Tank. Предназначен для изменения направления потока, ограничения давления рабочей жидкости гидролиниях, разгрузки насоса в нейтральной позиции золотников.

Specifications

Основные показатели:

1. Valve monoblock	моноблок
Конструктивное выполнение	3 bolts M10
2. Mounting	
Крепление	
3. Pressure connections	internal thread
Присоединительные отверстия	внутренние резьбы
4. Ambient temperature	-40C...+60C
Температура воздуха	
5. Pressure medium	mineral oil based hydraulic oil
Рабочая жидкость	
6. Viskosity	12...800 mm ² /s permissible range
Кинематическая вязкость	20...100 mm ² /s recommended range
7. Fluid temperature	- 15C...+80C
8. Filtration	Oil contamination 10 to NAS1638
9. Max. operating pressure	P = 250 bar
Давление max. bar	T = 50 bar
	A, B = 300 bar
10. Leakage	30 cm ³ /min at 120 bar
Внутренние потери (A, B – T)	
11. Nominal flow	120 l/min (see “operating” diagram)
Разход рабочей жидкости	
12. Spool stroke	± 10 mm, L12 = ± 10 mm +6 mm
Ход золотника	
13. Actuating force	< 300 N in spool axis direction

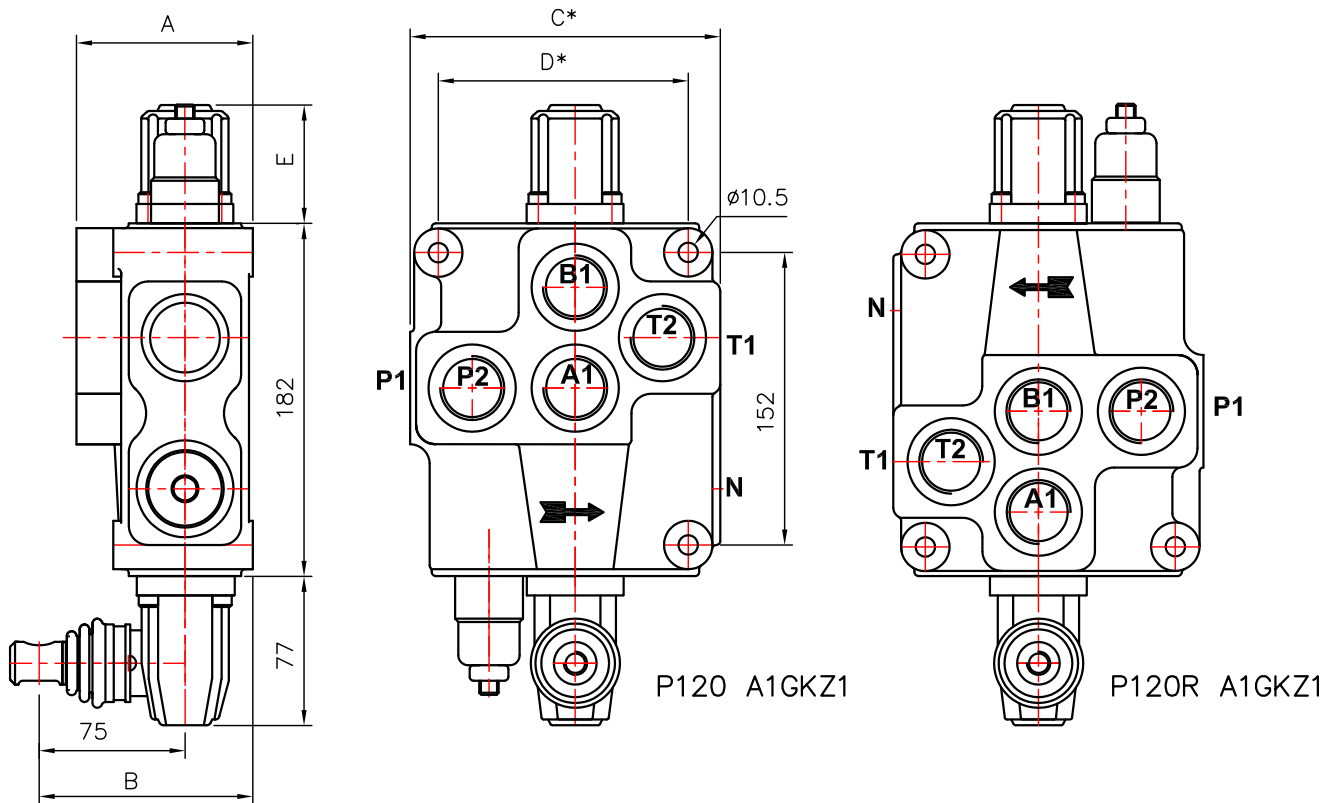

* for each next spool + 53 mm

Table 1

	A	B	C	D	P1	P2	T1	T2
P120	92	110	160	129	+	+	+	+

Table 2

spool control фиксации золотника	E
1; 2, 3, 4; 5; 6; 7; 8; 9; 10; 11;	64
12	74

02 P120 1 A 1 L 12 G KZ1 H E C2 -11

number of spools (table 3)

hydraulic directional control valve P120

parallel distribution (table 4) (parallel)

spool type—distribution (table 5)

spool control (table 6)

second spool distribution (table 5)

second spool control (table 6)

ports threads (table 9)

lever options (table 10)

operation features (table 8)

electric microswitch (table 7)

carry over center (table 11)

connection ports in use (table 12)

directional control valve P120

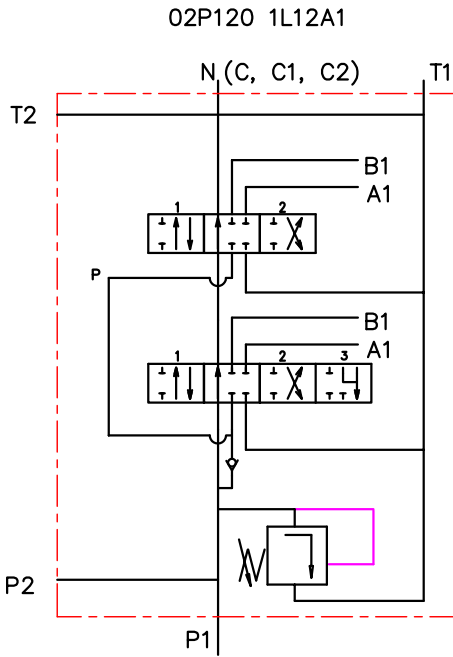

Table 3

code	Number of spools
P120	1
02P120	2

Table 4

code	way of distribution
	распределение потока
1	parallel ; параллельное

Table 5

code	spool type
A	
B	
C	
D	
E	
F	
G	
H	
M	
N	
O	
P	
Q	
R	
S	
T	
L	

Table 6

code	spool control
1	
2	
3	
4	
5	
6	
7	
8	
9	
10	
11	
12	
13	

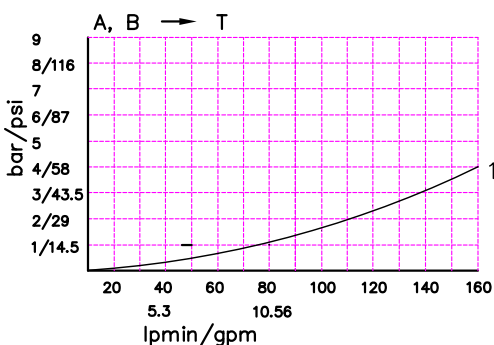
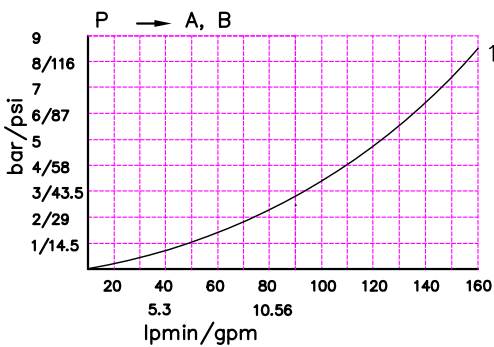
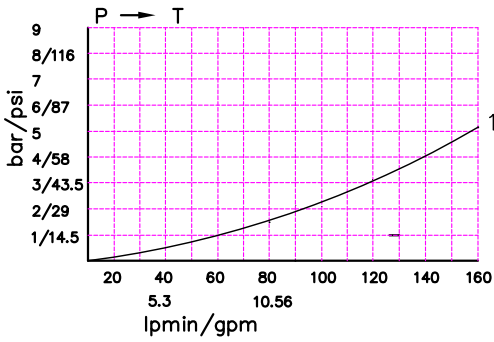

Table 7

code	с микро шалпер ; incorporated microswitch
E	<div style="display: inline-block; vertical-align: middle;"> mikroswitch type Omron-V 165 I C5 </div>

Table 8

code	другое управление ; operation feature
P	<div style="display: inline-block; vertical-align: middle;"> пневматическое on-off pneumatic control; 5-10 bar ; ports G1/4 </div>
H	<div style="display: inline-block; vertical-align: middle;"> гидравлическое on-off hydraulic control ; pn = 5 - 20 bar ; ports G1/4 </div>

directional control valve P120

treads for conection

Table 9

outlets/ports/	metric	BSP	SAE	NPT
P, A, B, T	M33x2	G 1"	SAE 16	1 - 11.5
N	M36x1.5	-	-	-

Table 10

code	with thread M12	code	with cange $\phi 12$	code	with cange $\phi 12$
KZ		KY		KI	
KZ1		KY1		KI1	
KZ0		KY0		KI0	
KZ01		KY01		KI01	

Table 11

code	metric
X	without N
-	with N, but closed
C	with N, closed center
C1	with N -carry over for ermeto
C2	with N-carry over, internal thread

Table 12

code	ports for connection in uze
11	P1 ; T1
12	P1 ; T2
21	P2 ; T1
21	P2 ; T1

