

7153

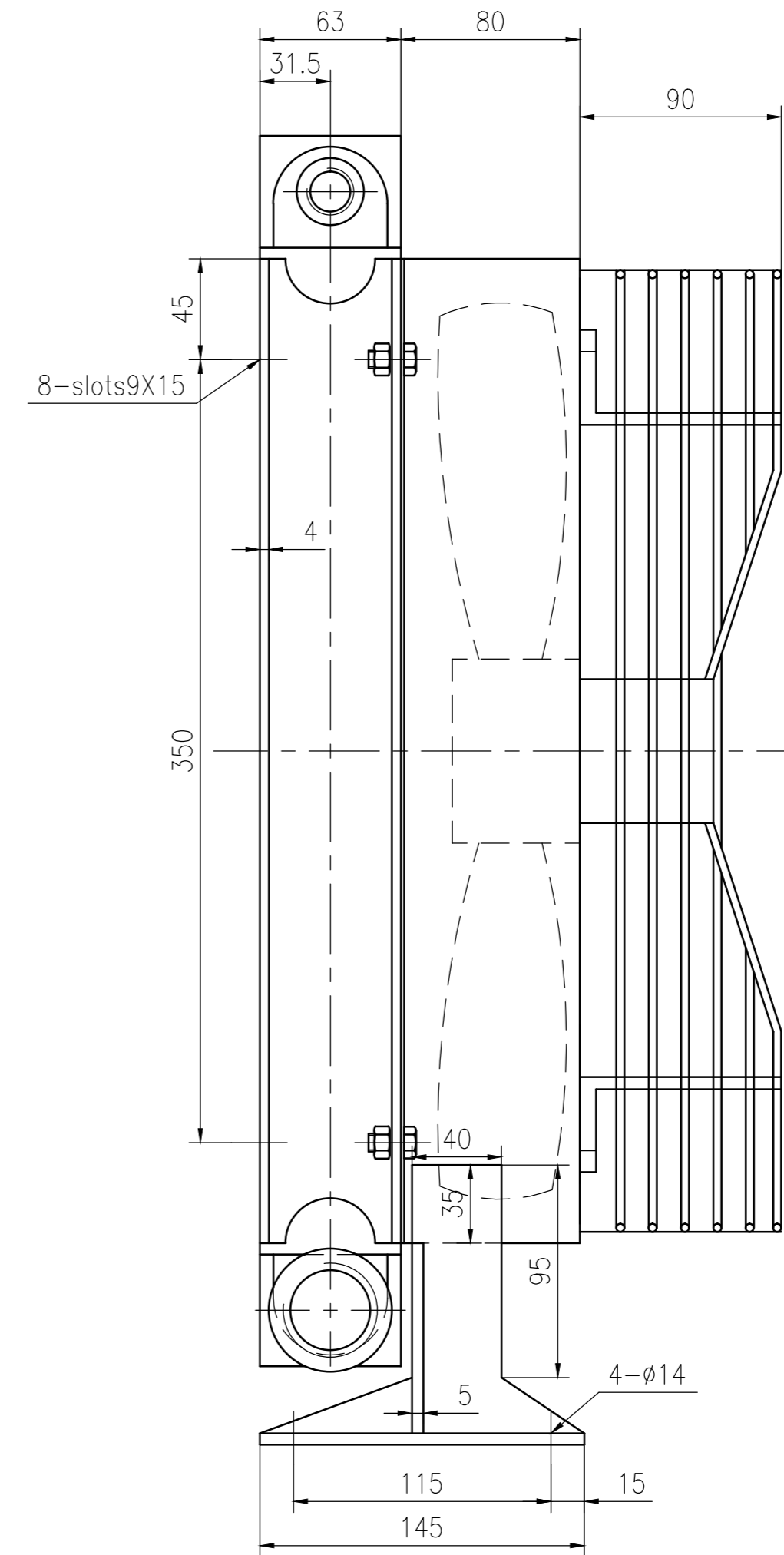
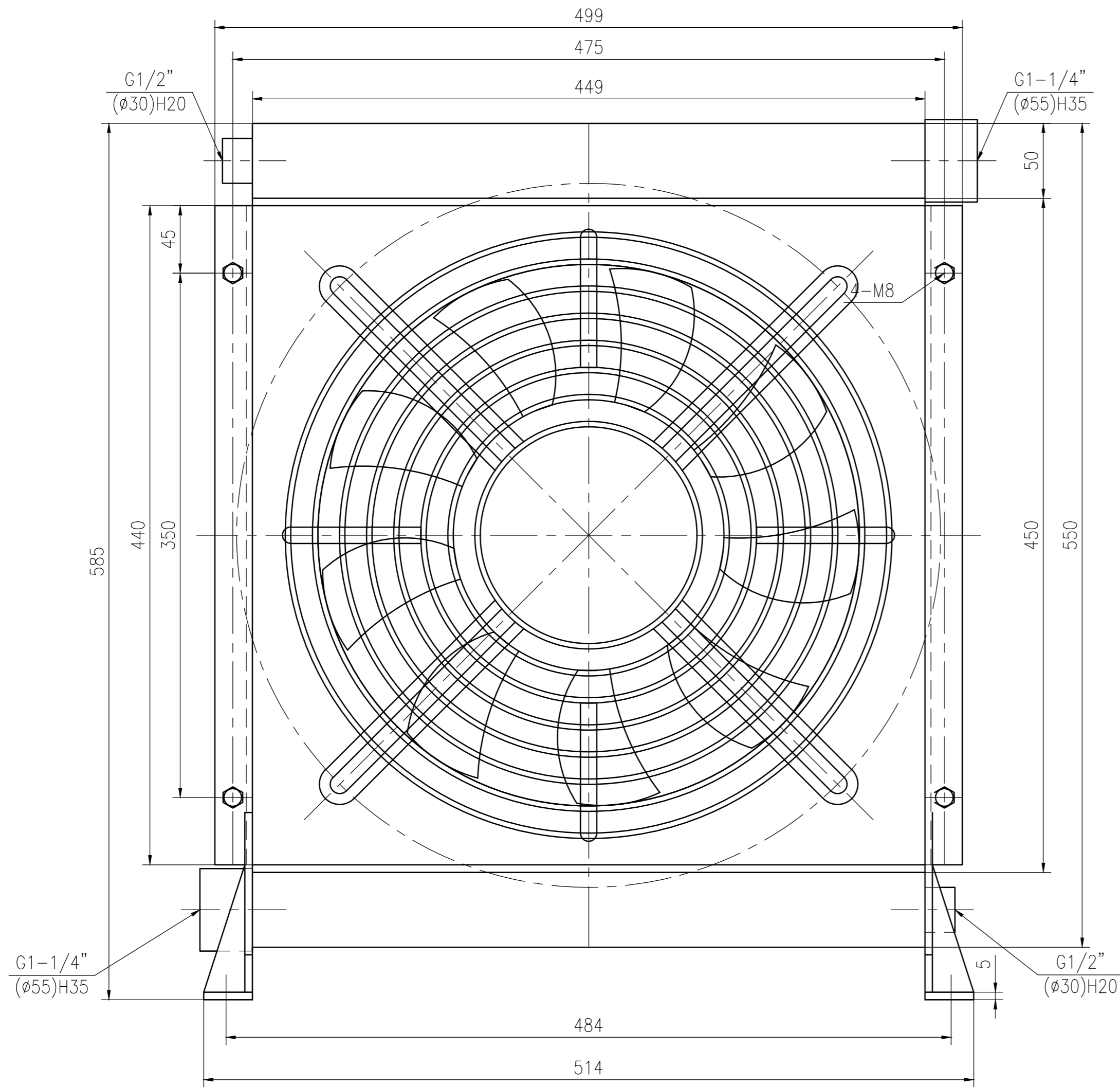

TECH REQUIREMENT

1. This product is made and confirmed according to NB/T47006-2009 technical specification of aluminum Bar-plate heat exchanger.
2. The argon-arc welding seam must be welded completely. There should not be any air vent and crackle in seam. Keep shape beautiful.
3. Water test pressure is 3.0Mpa for 5 minutes and no any leakage is allowed. Air test pressure is 1.0Mpa in the water for 15 minutes and no any leakage is allowed.
4. Appearance should not be knocked against and scratched seriously.
5. Dry up inside, clear appearance. Seal all port, black paint

风扇要求：电机220V，170W
风量3200m³/h

借通用件登记

描图

校描

旧底图总号

签字

日期

				Gin Stone(wuxi) Heat exchanger Technology Co.,Ltd		
				oil cooler		
				CSL4		
Mark No	Revision No	Signature	Date	Drawing Marking	Weight	Scale
Design		Standard Auditor				1:2.5
Reviewed by		Date		Total Page	Page of	
Technics						